



ДОРОГА
2019

16-18 ОКТЯБРЯ

МВЦ «ЕКАТЕРИНБУРГ-ЭКСПО»

Преимущества бетонных барьерных ограждений жесткого типа, установленных при помощи скользящих форм

Хуан-Луис Фумадо, Power Curbers & Power Pavers

ОПРЕДЕЛЕНИЕ:

Дорожное ограждение используется для того, чтобы безопасно изменить направление движения отклонившейся машины и увести от опасного фактора - например такого, как приближающаяся в противоположном направлении машина или опасных препятствий - таких, как деревья, скалы, дорожные знаки, опоры мостов, столбы, здания...



Power & Power
Curbers & Pavers

Our Commitment Shows

РАЗЛИЧНЫЕ ВИДЫ ОГРАЖДЕНИЙ:

Жесткие:

Прогиб 0.1 м

- Нью-Джерси (Пионер)
- F - образные
- Вертикальные
- С постоянным уклоном
- С одним уклоном

Полужесткие:

Прогиб 1.0 для расстояния 2.5 м

Гибкие:

Прогиб 2.0 для расстояния 2.5 м

- Гибкий трос (WRSB)
- Полужесткое стальное защитное ограждение W

Уровни испытаний по системе MASH

Уровень испытания	Автомобиль для испытания (Вес в килограммах)	Скорость км/час	Угол столкновения	Описание
TL1	Пассажирский автомобиль (1100) Грузовой автомобиль пикап (2250)	50 50	25 25	Зоны проведения работ с установленными низкими скоростями движения, очень низкий показатель ADT (среднесуточное число проходящих автомобилей), улицы местного значения с низкими скоростями движения
TL2	Пассажирский автомобиль (1100) Грузовой автомобиль пикап (2250)	70 70	25 25	Зоны проведения работ и магистральные дороги местного значения с благоприятными условиями, небольшой объем тяжелых транспортных средств, установленные скорости снижены.
TL3	Пассажирский автомобиль (1100) Грузовой автомобиль пикап (2250)	100 100	25 25	Высокоскоростные магистральные шоссе с небольшим объемом тяжелого транспорта и благоприятными условиями местности
TL4	Пассажирский автомобиль (1100) Грузовой автомобиль пикап (2250) Грузовой автомобиль без прицепа (9900)	100 100 90	25 25 15	Высокоскоростные магистрали, автострады, шоссе и автострады федерального значения с сочетанием грузовых автомобилей и тяжелого транспорта.
TL5	Пассажирский автомобиль (1100) Грузовой автомобиль пикап (2250) Тягач с прицепом-фургоном (35700)	100 100 80	25 25 15	Аналогично TL-4, но существенную часть среднесуточного числа проходящих автомобилей составляют большие грузовики
TL6	Пассажирский автомобиль (1100) Грузовой автомобиль пикап (2250) Тягач с прицепом-фургоном (35700)	100 100 80	25 25 15	Применение там, где предполагается движение автоцистерн или других автомобилей с высоким центром тяжести, особенно с неблагоприятными условиями местности.



Критерии эффективности MASH включают возможность системы принимать и перенаправлять энергию удара при аварии, риск для пассажира и траекторию движения автомобиля после столкновения.

Нормы Европейского Союза

CONTAINMENT LEVELS IN EN 1317-2

Containment levels			Acceptance test
Low angle containment	T1		TB 21
	T2		TB 22
	T3		TB 41 and TB 21
Normal containment	N1		TB 31
	N2		TB 32 and TB 11
Higher containment	H1		TB 42 and TB 11
	L1		TB 42 and TB32 and TB 11
	H2		TB 51 and TB 11
	L2		TB 51 and TB32 and TB 11
	H3		TB 61 and TB 11
	L3		TB 61 and TB32 and TB 11
Very high containment	H4a H4b		TB 71 and TB 11 TB 81 and TB 11
	L4a L4b		TB 71 and TB32 and TB 11 TB 81 and TB32 and TB 11

T1	T3	N1	N2	H1	H2	H3	H4a	H4b
1.300 kg 80 km/h Angulo 8°	10.000 kg 70 km/h Angulo 8°	1.500 kg 80 km/h Angulo 20°	1.500 kg 110 km/h Angulo 20°	10.000 kg 70 km/h Angulo 15°	13.000 kg 70 km/h Angulo 20°	16.000 kg 80 km/h Angulo 20°	30.000 kg 65 km/h Angulo 20°	38.000 kg 65 km/h Angulo 20°
TB 21	TB 41 + TB 21	TB 31	TB 32 + TB 11	TB 42 + TB 11	TB 51 + TB 11	TB 61 + TB 11	TB 71 + TB 11	TB 81 + TB 11



Power & Power
Curbers & Pavers

Our Commitment Shows

Нью-Джерси

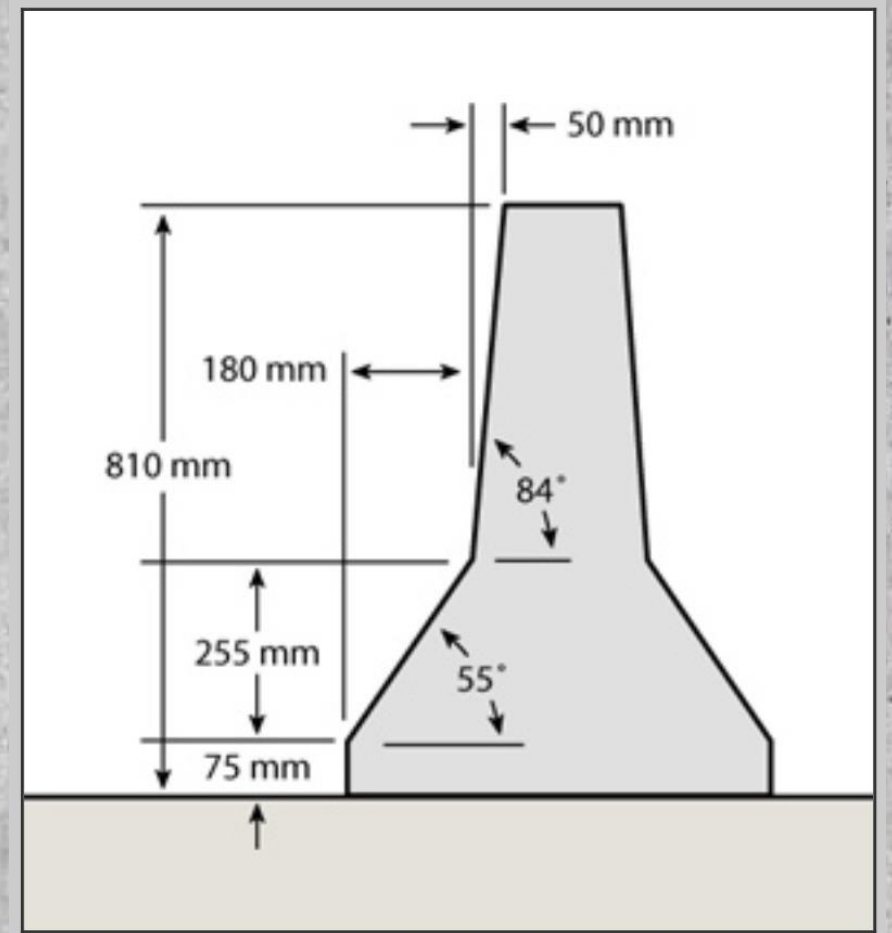

New Jersey Barrier Profile Dimensions

Power & Power
Curbers & Pavers

Our Commitment Shows

F образные ограждения



Уровень испытания	NCHP350	MASH
TL4	Высота 810 мм	Высота 910 мм
TL5	Высота 1060 мм	

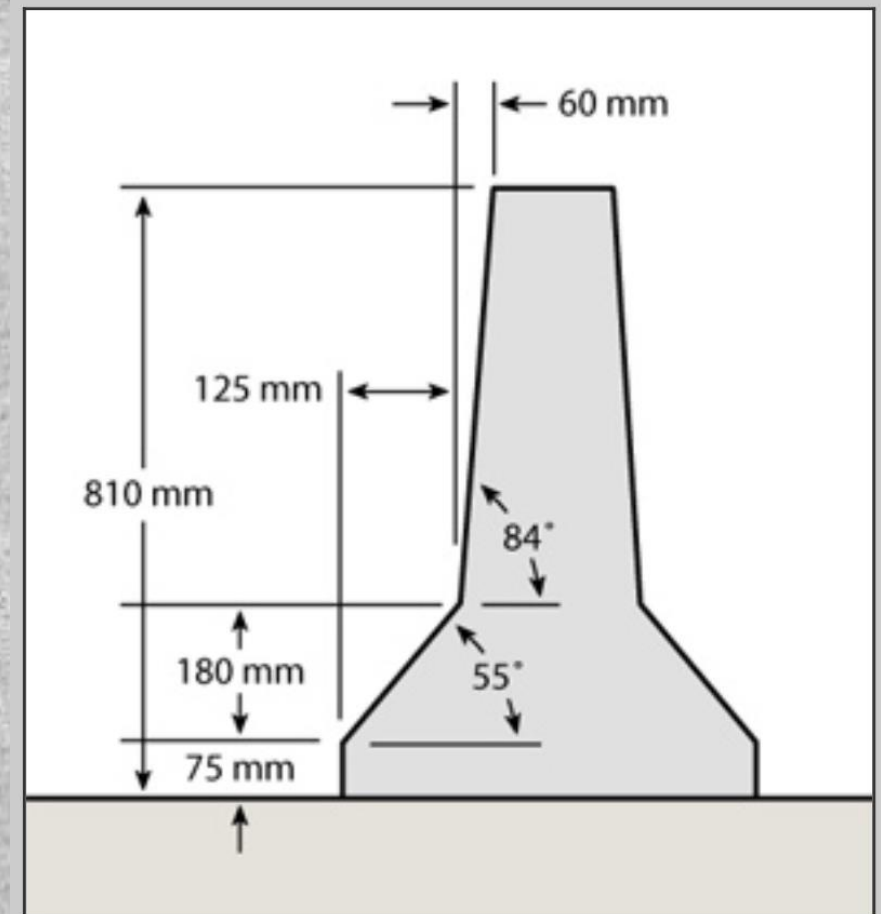

F Shape Barrier Profile Dimensions

Power & Power
Curbers & Pavers

Our Commitment Shows

Ограждение с постоянным уклоном

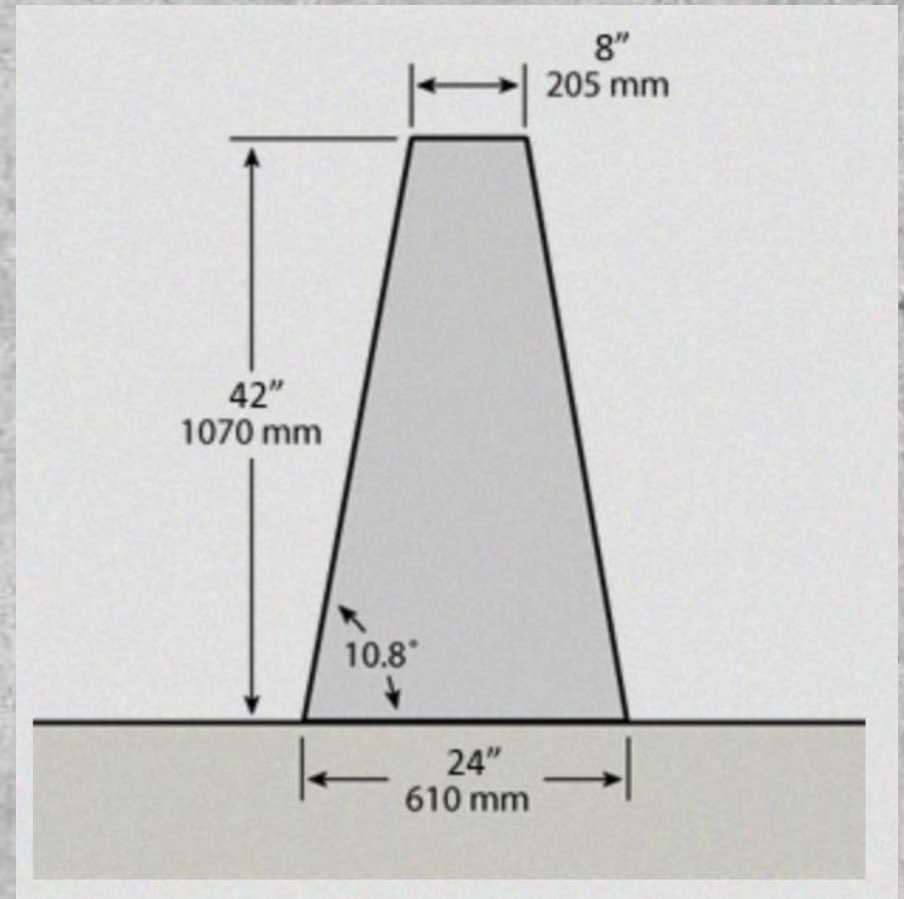

Power & Power
Curbers & Pavers

Our Commitment Shows

Ограждение с одним уклоном

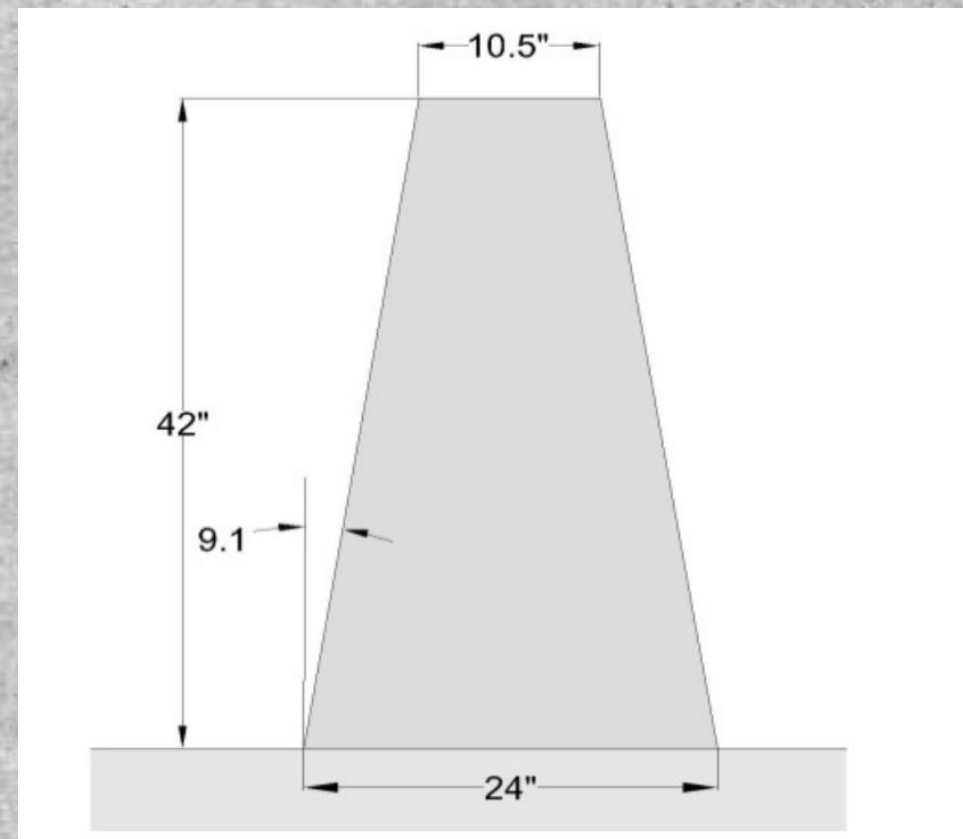

Уровень испытания	NCHRP350	MASH
TL4	Высота 810 мм	Высота 910 мм
TL5	Высота 1060 мм	

Бетонное ступенчатое ограждение (CSB)

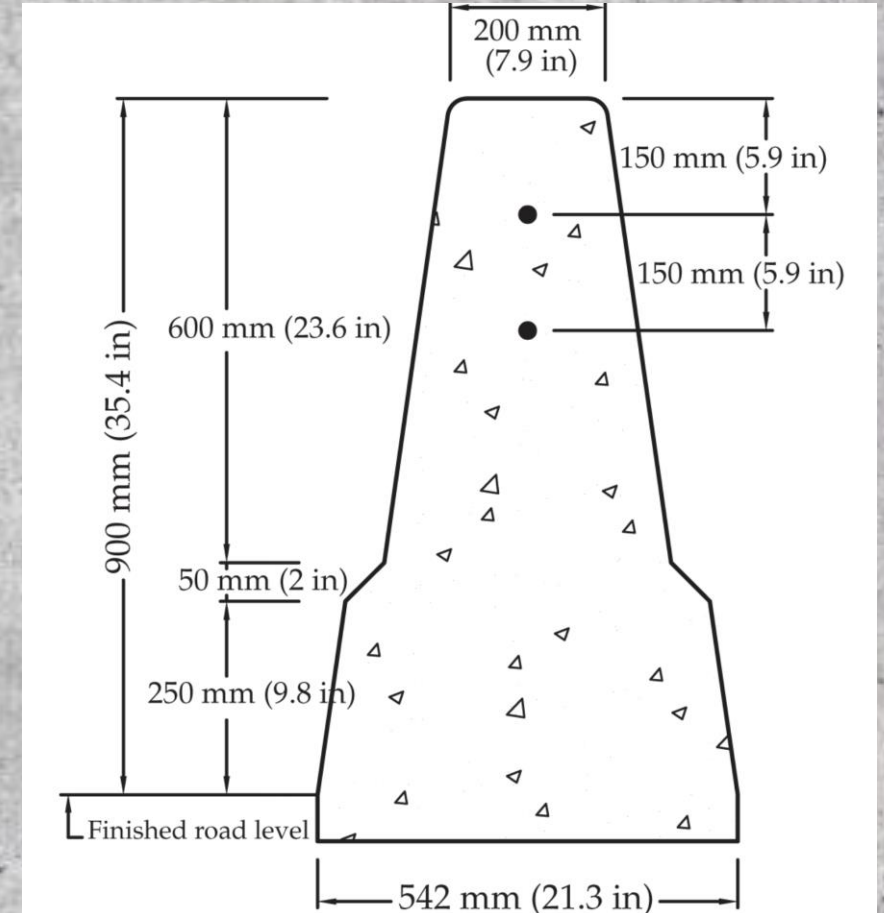



EP IN-SITU BARRIERS
ON THE M1 80, UNITED KINGDOM

DELTABLOC®

EP 80B IN-SITU BARRIER

Technical Specifications

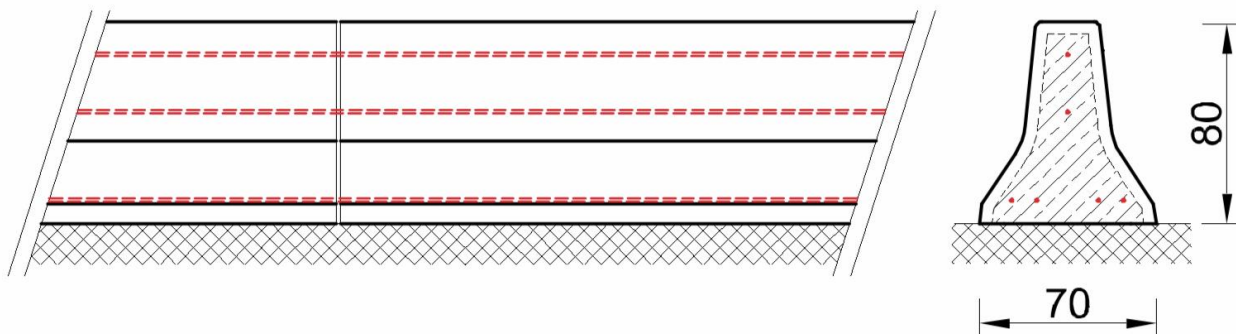

Ограждение DELTABLOC

Power & Power
Curbers & Pavers

Our Commitment Shows

Ограждение BRITRAVE BBS

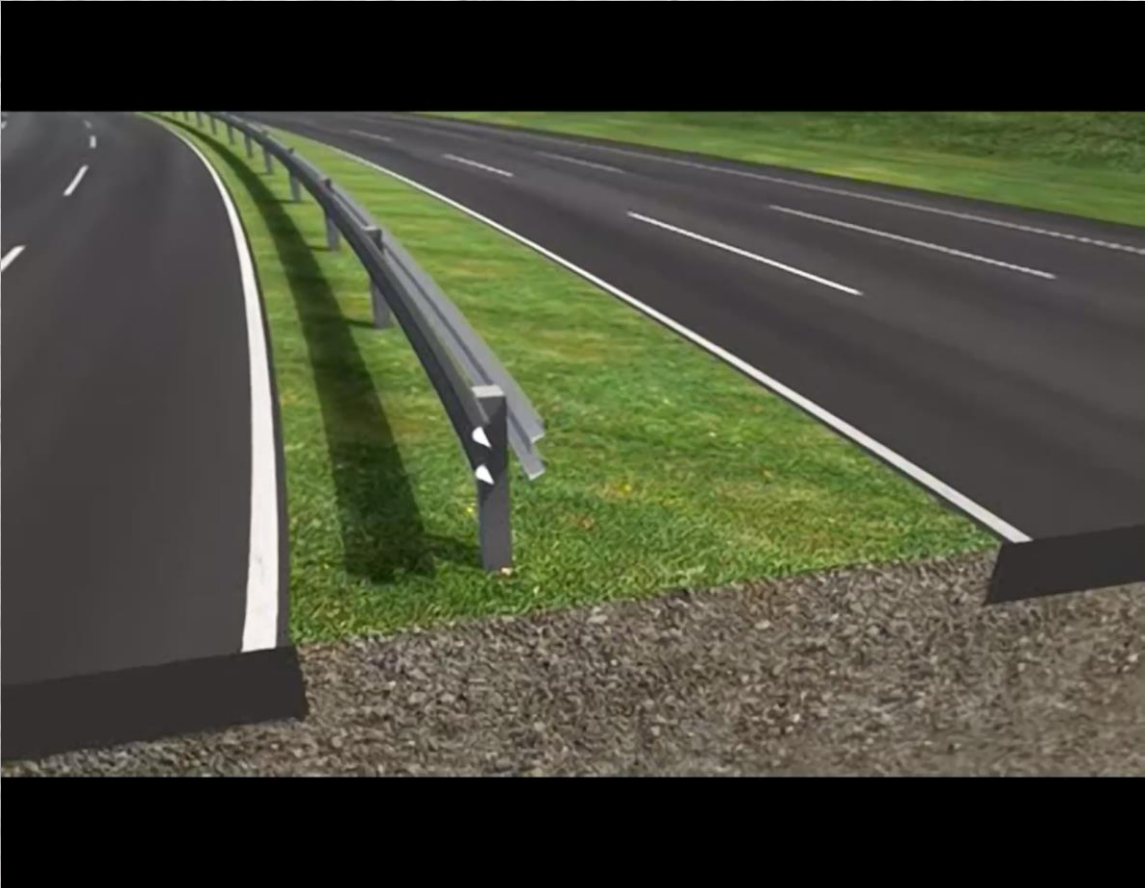

Почему мы говорим о бетонных ограждениях:



Power & Power
Curbers & Pavers
Our Commitment Shows

Google фото: аварии при металлических дорожных ограждениях.

The image is a screenshot of a Google search results page for the query "guard rail accident". The search bar is at the top, with the Google logo and search filters. Below the search bar, there are several tabs for "TODO", "IMÁGENES", "NOTICIAS", "VÍDEOS", "MAPS", "SHOPPING", "LIBROS", "VUELOS", and "PERSONAL". The "IMÁGENES" tab is selected. Below the tabs, there are several suggested search terms: "san diego", "caltrans", "crash tests", "clarkville tn", "guardrails", "car", "driver", "bmw 335i", "highway", "car accident", "youtube", "suv", "lawsuit", "crash test", and "et plus". The main content area is a grid of search results, including images and video thumbnails. The results are organized into columns. The first column contains several video thumbnails with titles like "I-Team: New study confirms deadly guardrail...", "Driver Survives After Car Is Impaled By Gu...", "A Pennsylvania Driver Somehow Survived...", "Guard Rail Accidents - Coffey Trial Law", "Horrific Car Accidents Blamed on Faulty G...", and "30 states ban dangerous guardrails | MNN...". The second column contains images and video thumbnails with titles like "Amazing crash: BMW 335i hits guard rail, ...", "Highway accidents from defective guardrail...", "NSW man nearly dies after a guard rail pier...", "Man killed after guard rail smashes throu...", "Woman faces DWI charges after guard rail ...", "SUV impaled by guardrail in crash, but its ...", "WOMAN KILLED BY GUARDRAIL IN ACCI...", "Tesla Sued By Family Of Silicon Valley Driv...", "Un auto se despiató y se incrustó contra u...", "Analysis of Extruding W-Beam Guar...", "Development of a Heavy Containment Lev...", "Guardrail end caps fail to meet safety exp...", "Here's why poorly designed guard rails are...", "Brutal Accident: Divider railing (Guardrail) ...", "Attleboro firefighters rescue driver pinned L...", "Chaotic 911 calls released from deadly tra...", "End-Terminal for Open Box-Beam Guarda...", "911 PHOTOGRAPHY", "Auto chocó y el guardrail se incrustó en su...", "3 hospitalized after Greensboro crash", "Car crashes into guardrail on US-35", "Car swerves to avoid deer, slams into guar...", "Wild Guard Rail Accident", and "BPD: Intoxicated driver splits pickup truck ...". The third column contains images and video thumbnails with titles like "Guardrail May Be Deadly, States...", "Attleboro firefighters rescue driver pinned L...", "Development of a Heavy Containment Lev...", "Guardrail end caps fail to meet safety exp...", "Here's why poorly designed guard rails are...", "Brutal Accident: Divider railing (Guardrail) ...", "Attleboro firefighters rescue driver pinned L...", "Chaotic 911 calls released from deadly tra...", "End-Terminal for Open Box-Beam Guarda...", "911 PHOTOGRAPHY", "Auto chocó y el guardrail se incrustó en su...", "3 hospitalized after Greensboro crash", "Car crashes into guardrail on US-35", "Car swerves to avoid deer, slams into guar...", "Wild Guard Rail Accident", and "BPD: Intoxicated driver splits pickup truck ...". The fourth column contains images and video thumbnails with titles like "Guardrail May Be Deadly, States...", "Attleboro firefighters rescue driver pinned L...", "Development of a Heavy Containment Lev...", "Guardrail end caps fail to meet safety exp...", "Here's why poorly designed guard rails are...", "Brutal Accident: Divider railing (Guardrail) ...", "Attleboro firefighters rescue driver pinned L...", "Chaotic 911 calls released from deadly tra...", "End-Terminal for Open Box-Beam Guarda...", "911 PHOTOGRAPHY", "Auto chocó y el guardrail se incrustó en su...", "3 hospitalized after Greensboro crash", "Car crashes into guardrail on US-35", "Car swerves to avoid deer, slams into guar...", "Wild Guard Rail Accident", and "BPD: Intoxicated driver splits pickup truck ...". The fifth column contains images and video thumbnails with titles like "Guardrail May Be Deadly, States...", "Attleboro firefighters rescue driver pinned L...", "Development of a Heavy Containment Lev...", "Guardrail end caps fail to meet safety exp...", "Here's why poorly designed guard rails are...", "Brutal Accident: Divider railing (Guardrail) ...", "Attleboro firefighters rescue driver pinned L...", "Chaotic 911 calls released from deadly tra...", "End-Terminal for Open Box-Beam Guarda...", "911 PHOTOGRAPHY", "Auto chocó y el guardrail se incrustó en su...", "3 hospitalized after Greensboro crash", "Car crashes into guardrail on US-35", "Car swerves to avoid deer, slams into guar...", "Wild Guard Rail Accident", and "BPD: Intoxicated driver splits pickup truck ...". The sixth column contains images and video thumbnails with titles like "Guardrail May Be Deadly, States...", "Attleboro firefighters rescue driver pinned L...", "Development of a Heavy Containment Lev...", "Guardrail end caps fail to meet safety exp...", "Here's why poorly designed guard rails are...", "Brutal Accident: Divider railing (Guardrail) ...", "Attleboro firefighters rescue driver pinned L...", "Chaotic 911 calls released from deadly tra...", "End-Terminal for Open Box-Beam Guarda...", "911 PHOTOGRAPHY", "Auto chocó y el guardrail se incrustó en su...", "3 hospitalized after Greensboro crash", "Car crashes into guardrail on US-35", "Car swerves to avoid deer, slams into guar...", "Wild Guard Rail Accident", and "BPD: Intoxicated driver splits pickup truck ...". The seventh column contains images and video thumbnails with titles like "Guardrail May Be Deadly, States...", "Attleboro firefighters rescue driver pinned L...", "Development of a Heavy Containment Lev...", "Guardrail end caps fail to meet safety exp...", "Here's why poorly designed guard rails are...", "Brutal Accident: Divider railing (Guardrail) ...", "Attleboro firefighters rescue driver pinned L...", "Chaotic 911 calls released from deadly tra...", "End-Terminal for Open Box-Beam Guarda...", "911 PHOTOGRAPHY", "Auto chocó y el guardrail se incrustó en su...", "3 hospitalized after Greensboro crash", "Car crashes into guardrail on US-35", "Car swerves to avoid deer, slams into guar...", "Wild Guard Rail Accident", and "BPD: Intoxicated driver splits pickup truck ...". The eighth column contains images and video thumbnails with titles like "Guardrail May Be Deadly, States...", "Attleboro firefighters rescue driver pinned L...", "Development of a Heavy Containment Lev...", "Guardrail end caps fail to meet safety exp...", "Here's why poorly designed guard rails are...", "Brutal Accident: Divider railing (Guardrail) ...", "Attleboro firefighters rescue driver pinned L...", "Chaotic 911 calls released from deadly tra...", "End-Terminal for Open Box-Beam Guarda...", "911 PHOTOGRAPHY", "Auto chocó y el guardrail se incrustó en su...", "3 hospitalized after Greensboro crash", "Car crashes into guardrail on US-35", "Car swerves to avoid deer, slams into guar...", "Wild Guard Rail Accident", and "BPD: Intoxicated driver splits pickup truck ...". The ninth column contains images and video thumbnails with titles like "Guardrail May Be Deadly, States...", "Attleboro firefighters rescue driver pinned L...", "Development of a Heavy Containment Lev...", "Guardrail end caps fail to meet safety exp...", "Here's why poorly designed guard rails are...", "Brutal Accident: Divider railing (Guardrail) ...", "Attleboro firefighters rescue driver pinned L...", "Chaotic 911 calls released from deadly tra...", "End-Terminal for Open Box-Beam Guarda...", "911 PHOTOGRAPHY", "Auto chocó y el guardrail se incrustó en su...", "3 hospitalized after Greensboro crash", "Car crashes into guardrail on US-35", "Car swerves to avoid deer, slams into guar...", "Wild Guard Rail Accident", and "BPD: Intoxicated driver splits pickup truck ...". The tenth column contains images and video thumbnails with titles like "Guardrail May Be Deadly, States...", "Attleboro firefighters rescue driver pinned L...", "Development of a Heavy Containment Lev...", "Guardrail end caps fail to meet safety exp...", "Here's why poorly designed guard rails are...", "Brutal Accident: Divider railing (Guardrail) ...", "Attleboro firefighters rescue driver pinned L...", "Chaotic 911 calls released from deadly tra...", "End-Terminal for Open Box-Beam Guarda...", "911 PHOTOGRAPHY", "Auto chocó y el guardrail se incrustó en su...", "3 hospitalized after Greensboro crash", "Car crashes into guardrail on US-35", "Car swerves to avoid deer, slams into guar...", "Wild Guard Rail Accident", and "BPD: Intoxicated driver splits pickup truck ...".

Power & Pavers
Our Commitment Shows

Некачественная установка или техническое обслуживание.



Факторы выбора правильного дорожного ограждения

- Тип автомобиля.
- Геометрия дороги.
- Потенциальная тяжесть в случае аварии.
- Скорость движения.

Бетонные ограждения заводского изготовления или скользящая форма

- Экономический аспект



- Безопасность



Этапы установки ограждений заводского изготовления



Power & Power
Curbers & Pavers
Our Commitment Shows

Отливка бетонных ограждений при помощи скользящей формы



Порядок производства при помощи скользящей формы

- Осадка конуса от 20 до 40 мм
- Воздух в смеси от 4 до 6%
- Усадочные швы каждые 2 - 3,5 м
- Расширительные швы каждые 25 - 35 м
- Нарезка швов на свежем бетоне
- Вибраторы в бункере формы не мешают потоку бетона.

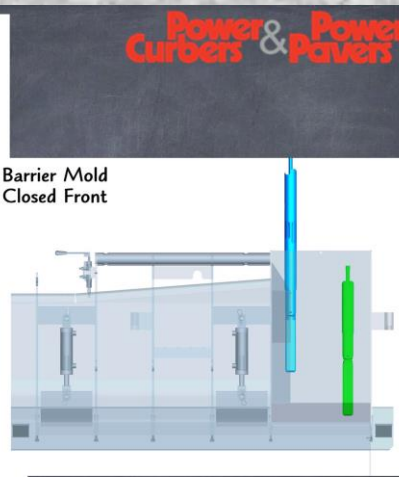
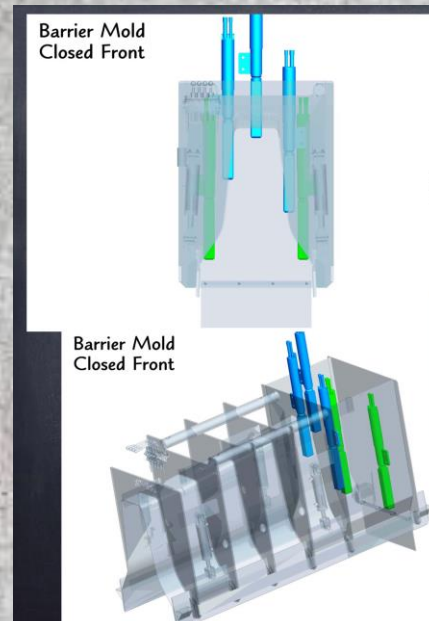
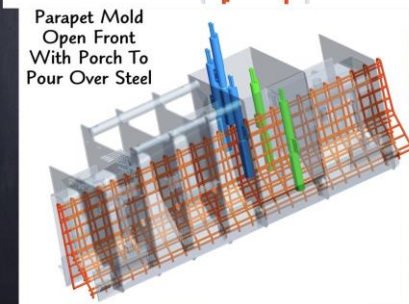
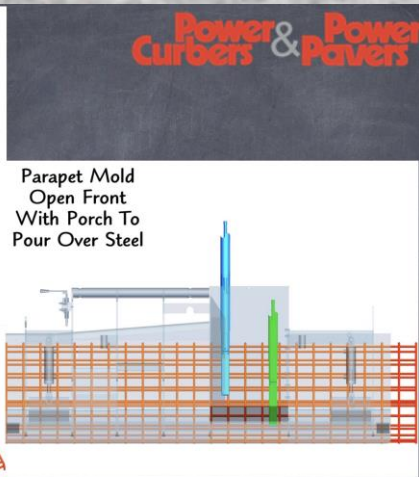
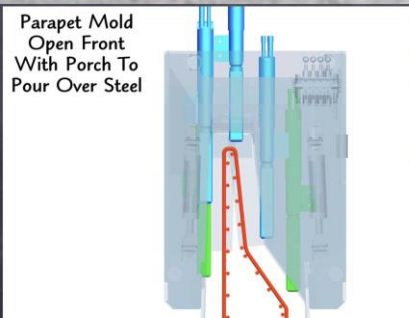

Деформационные швы

Расширительный шов:



До

После

Усадочный шов:



До

После

Производственные затраты

Заводское изготовление :

- Покупка блоков
- Транспортировка блоков
- Хранение блоков
- Строительство основания
- Транспортировка со склада к основанию
- Установка
- Устанавливают максимум 100 м/день
- Активно применяется ручной труд.

Скользкая форма:

- Транспортировка машины
- Подача бетона в машину
- Производительность более 600 -1000 м/день
- Применение ручного труда требуется в незначительной степени



Краш-тест с использованием ограждений заводского изготовления, США



Power & Power
Curbers & Pavers

Our Commitment Shows

Краш-тест с использованием ограждений, изготовленных при помощи скользящей формы, США



Испытание в ЕС ограждений DELTABLOC заводского изготовления

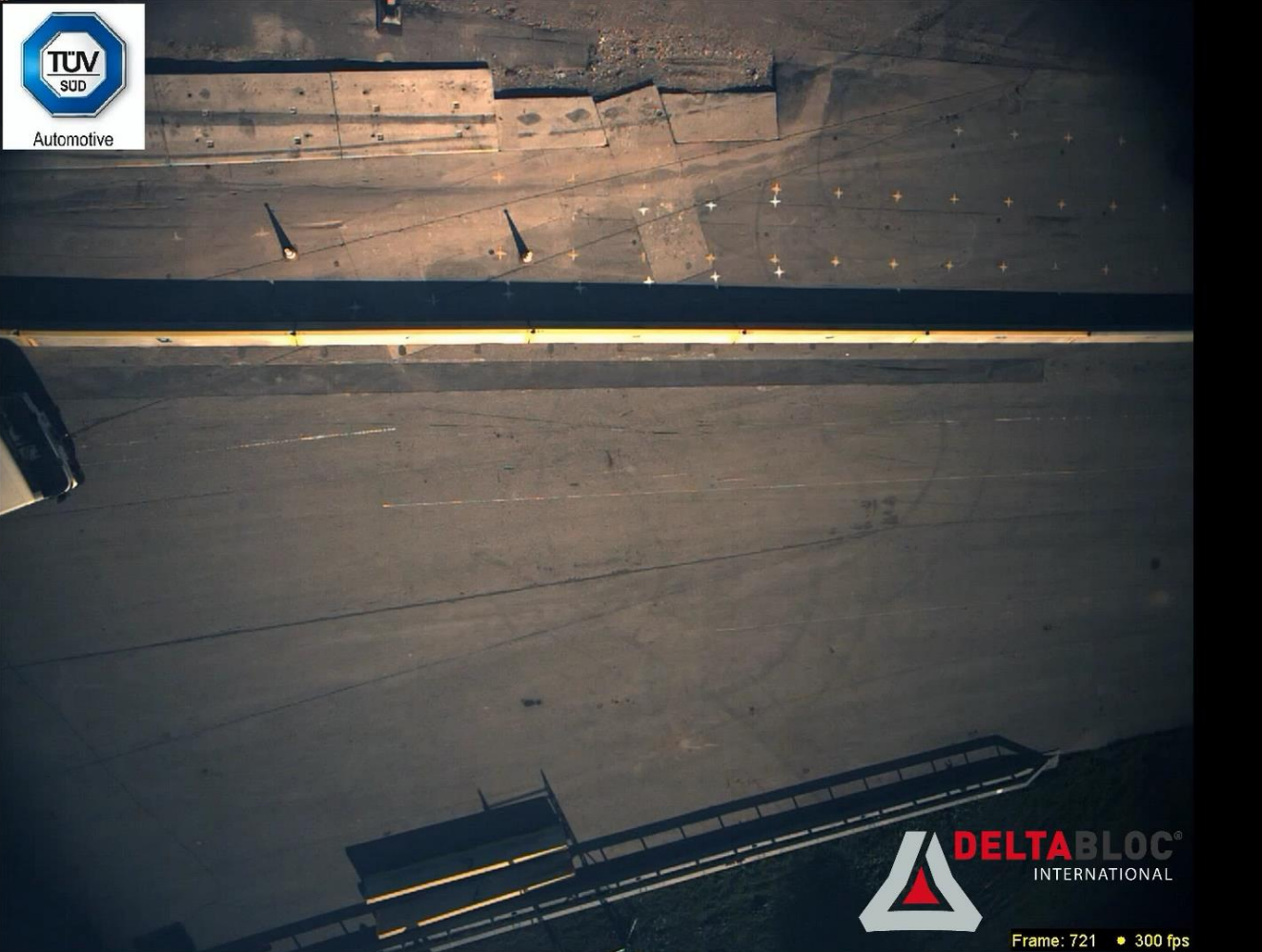

DELTABLOC® **DB 80AS** GENERATION 1

Technical Product Data Sheet

					L1	L2	L3	L4a	L4b
T1	T2	T3	N1	N2	H1	H2	H3	H4a	H4b

The vehicle restraint system DB 80AS / 6m H2|W7 is used for the double-rowed securing of central reservations of motorways. The trough behind the two rows is filled, thereby increasing the breakthrough stability while maintaining maximum flexibility.

The DB 80AS / 4m N2|W4, however, is used for the single-rowed installation for the safeguarding of verges of dual carriageways.

Main features

- ▶ high breakthrough prevention
- ▶ high vehicle passenger protection (ASI B)
- ▶ in double-rowed installation blinding guard by vegetation planting possible
- ▶ clear lines when used within the DB 80 product family
- ▶ cost-efficient securing of the marginal strip of the road

Испытание в ЕС ограждений DELTABLOC заводского изготовления



DELTABLOC® **EP 80B** IN-SITU BARRIER

Technical Product Data Sheet

					L1	L2	L3	L4a	L4b
T1	T2	T3	N1	N2	H1	H2	H3	H4a	H4b

The in-situ concrete system EP 80B is a vehicle restraint system with a modern in-situ-concrete design that can be mounted on asphalt and gravel surfaces.

With the impact severity level ASI B this system offers optimum passenger safety in combination with high restraint safety and a small working width.

Main features

- ▶ ASI B according to EN 1317-1:2011
- ▶ H2|W2 on asphalt surface, H2|W3 on gravel surface
- ▶ reinforcing elements protected against corrosion
- ▶ crash tested with contraction joints without spalling
- ▶ reconstruction according to norm in case of damage

Power & Power
Curbers & Pavers

Our Commitment Shows

Выводы:

Бетонные ограждения, выполненные при помощи скользящих форм

- Более дешевое и быстрое строительство.
- Большая длина ограждения за те же инвестиции.
- Более высокая удерживающая способность благодаря монолитности.
- Не передают аварию на другую полосу движения .
- Меньше выбросы CO₂.

Бетонные ограждения заводского изготовления:

- Гибкость, поглощает часть энергии столкновения.
- Перемещаемые.

Улучшение безопасности бетонных жестких ограждений



Очень важно в начале ограждений устанавливать системы, поглощающие энергию, чтобы избежать прямых передних столкновений с жесткими ограждениями.

Снег не проблема для бетонных ограждений



Power & Power
Curbers & Pavers
Our Commitment Shows

Снег не проблема для бетонных ограждений



Power & Power
Curbers & Pavers
Our Commitment Shows

Большое спасибо!

Juan-Luis Fumadó
(Хуан-Луис Фумадо)